

Curvilinear Double Nest

Product information

Product description

Discover adventure with the Curvilinear Double Nest Playground, featuring two way towers connected by pipe structure and play elements. Slide between the towers, lounge on the giant hammock, or swing on the triangle hammocks for endless fun. Perfect for parks and community spaces, this playground combines active play with relaxation for kids .

Category	: Net Playground
Age group	: 6-12 years old
Product Code	: CV0118SM
Sizes (mm)	: L32640 x H3684 x W7713 mm

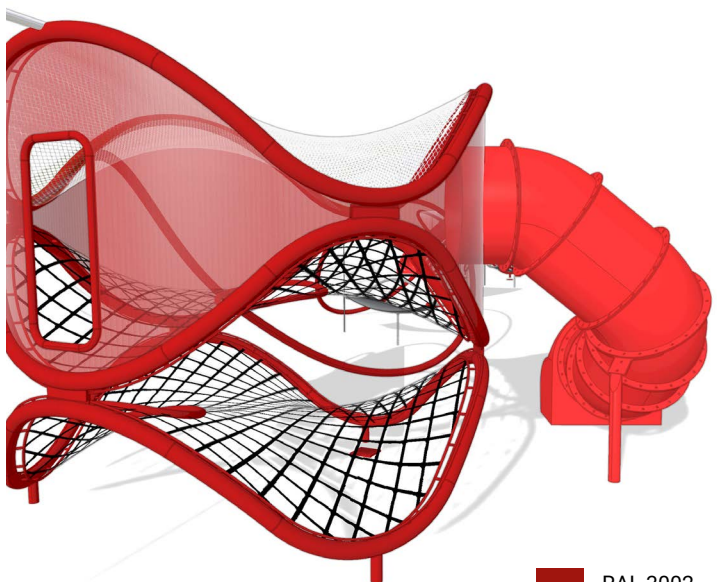

 RAL 3002
Carmine Red

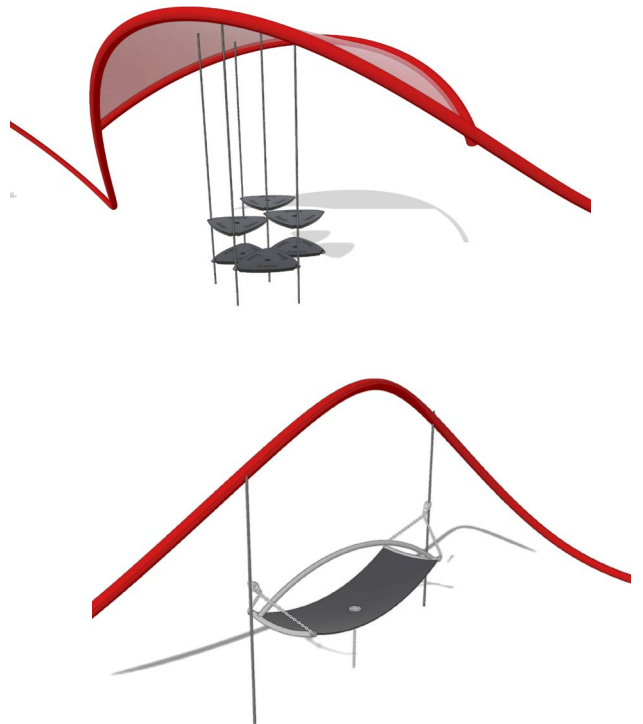

As part of our commitment to continuous product improvement, Copyright © Kinetics Play Sdn Bhd reserves the right to modify product specifications without prior notice. All drawings and visuals are property of Kinetics Play Sdn Bhd or used under license and may not be reproduced without written consent.

KINETICS PLAY SDN. BHD. (1223254-U)

Lot 2-44 Jalan SU7, Lion Industrial Park, Persiaran Tengku Ampuan, 40300 Shah Alam, Selangor, Malaysia.
Tel: +603-5888 9104 Email: info@kineticsplay.com Web: www.kineticsplay.com

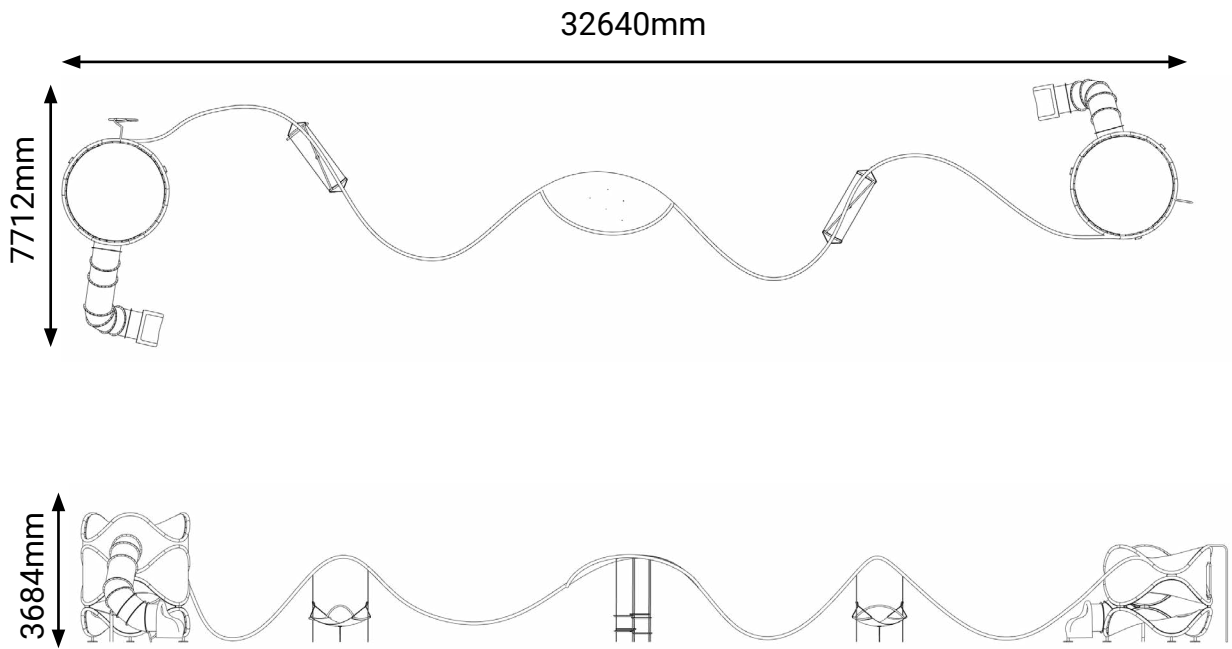
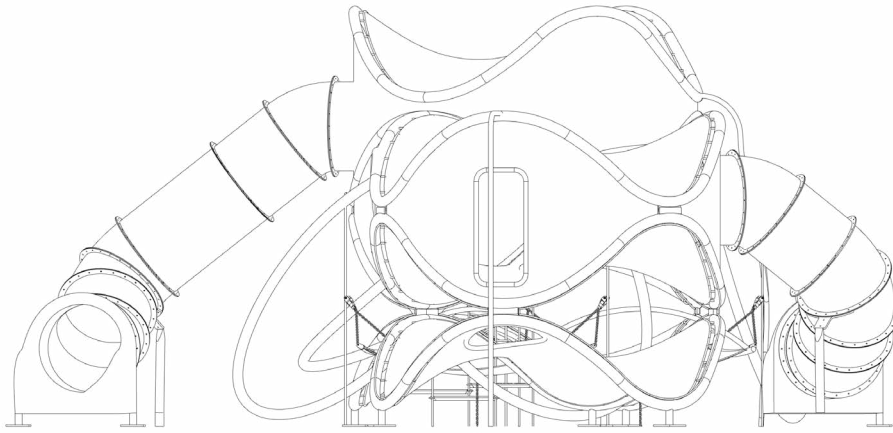

As part of our commitment to continuous product improvement, Copyright © Kinetics Play Sdn Bhd reserves the right to modify product specifications without prior notice. All drawings and visuals are property of Kinetics Play Sdn Bhd or used under license and may not be reproduced without written consent.

KINETICS PLAY SDN. BHD. (1223254-U)

Lot 2-44 Jalan SU7, Lion Industrial Park, Persiaran Tengku Ampuan, 40300 Shah Alam, Selangor, Malaysia.
Tel: +603-5888 9104 Email: info@kineticsplay.com Web: www.kineticsplay.com