



Whoosh Double Loop

Product information

Product description

Whoosh is designed with sleek and fluid characteristics within its three-dimensional netting. It offers children who climb, crawl or roll in it truly different perspectives and adventurous climbing experiences; developing confidence, motor skills and spatial awareness.

Category	: Net Playground
Age group	: 2-5 years old
Product Code	: CVWO002
Sizes (mm)	: L9900 x H1770 x W5200 mm

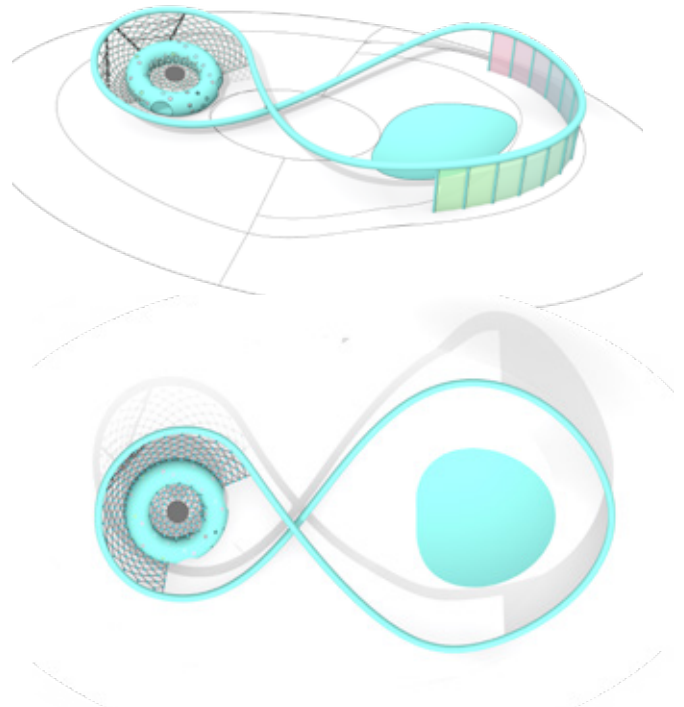
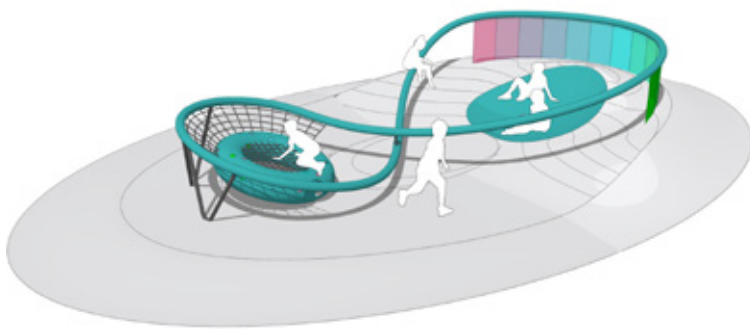

As part of our commitment to continuous product improvement, Copyright © Kinetics Play Sdn Bhd reserves the right to modify product specifications without prior notice. All drawings and visuals are property of Kinetics Play Sdn Bhd or used under license and may not be reproduced without written consent.

KINETICS PLAY SDN. BHD. (1223254-U)

Lot 2-44 Jalan SU7, Lion Industrial Park, Persiaran Tengku Ampuan, 40300 Shah Alam, Selangor, Malaysia.
Tel: +603-5888 9104 Email: info@kineticsplay.com Web: www.kineticsplay.com

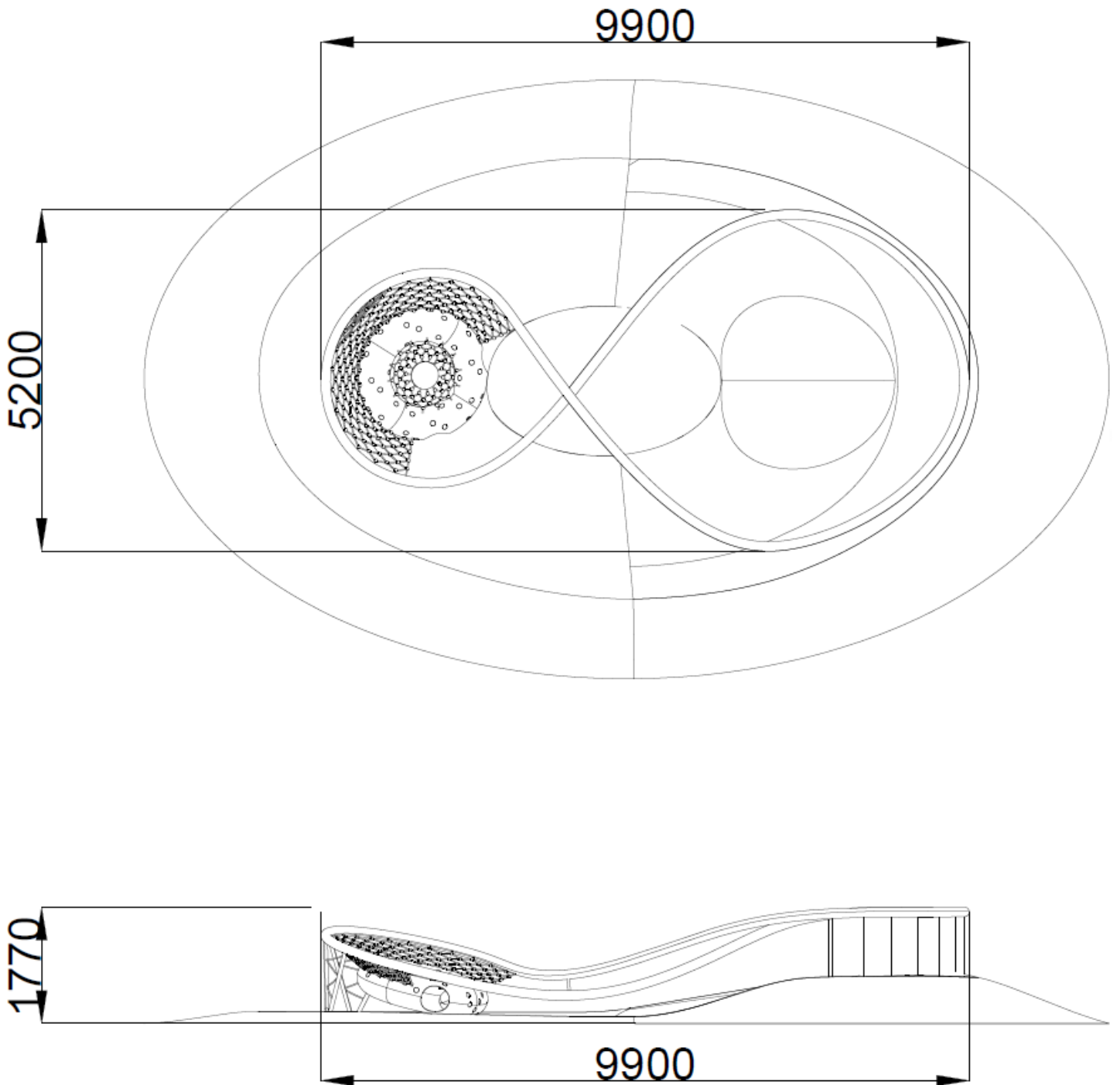

As part of our commitment to continuous product improvement, Copyright © Kinetics Play Sdn Bhd reserves the right to modify product specifications without prior notice. All drawings and visuals are property of Kinetics Play Sdn Bhd or used under license and may not be reproduced without written consent.

KINETICS PLAY SDN. BHD. (1223254-U)

Lot 2-44 Jalan SU7, Lion Industrial Park, Persiaran Tengku Ampuan, 40300 Shah Alam, Selangor, Malaysia.
Tel: +603-5888 9104 Email: info@kineticsplay.com Web: www.kineticsplay.com