

## BL1000 PARALLEL BARS

### Product Information

#### Product Description

Parallel bars are great for working out the triceps, chest and shoulders, especially the Anterior Deltoids. Consistent training will result in greater upper body strength and flexibility.

Category	: Kinetics Fitness Equipment
Age group	: 16yrs & above
Size (mm)	: 2455L x 685W x 990H
Maximum users	: 1 user
Weight	: 45 kg

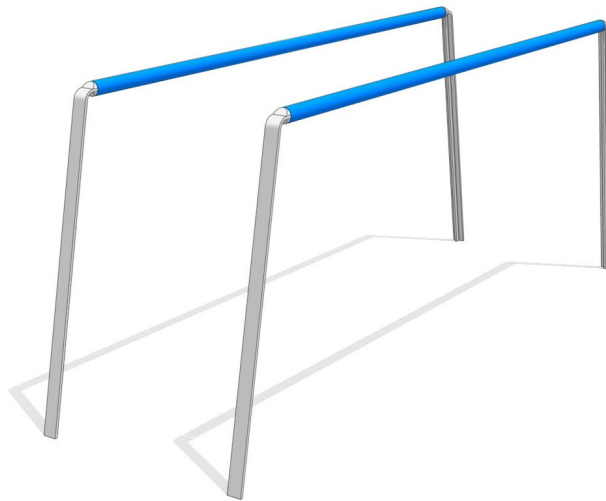

We will continue to make product improvement and reserve the right to change design specification without notice.

tuv-sud.com/pe-cert  
Certification No. Z2 102633 0001

#### Kinetics Play Sdn Bhd

Lot 2-44, Jalan SU7, Lion Industrial Park, Persiaran Tengku Ampuan, 40300 Shah Alam, Selangor, Malaysia.  
Tel: +603-5888 9104

Email: [info@kineticsplay.com](mailto:info@kineticsplay.com)

Web: [www.kineticsplay.com](http://www.kineticsplay.com)

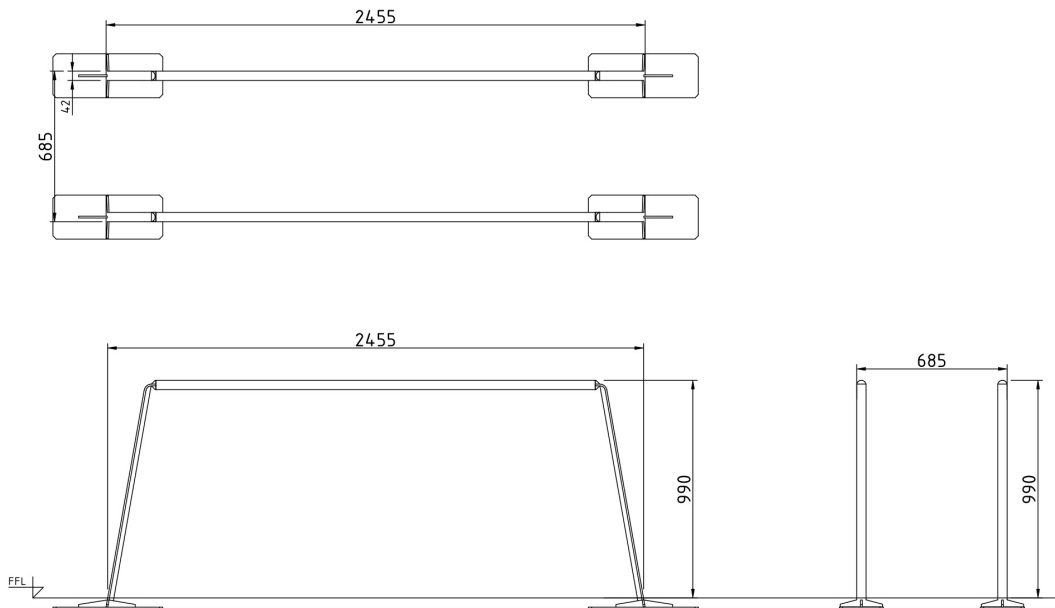
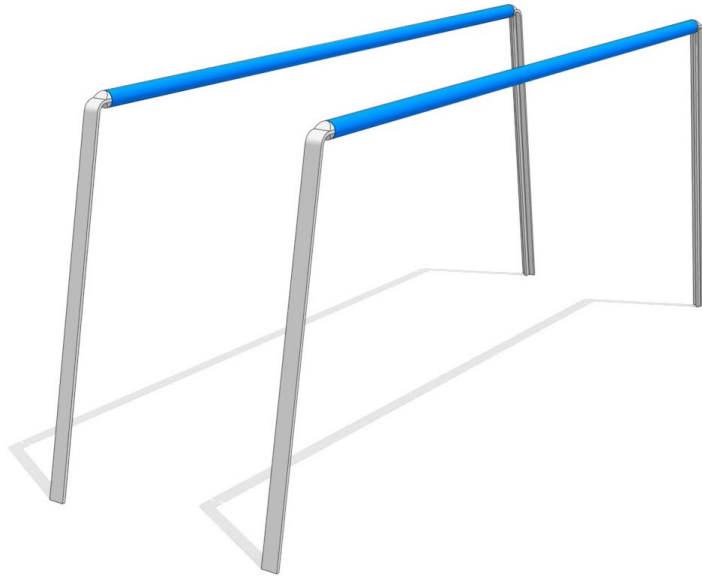

Instructional graphic on Standalone (BL003)



Instructional Signage

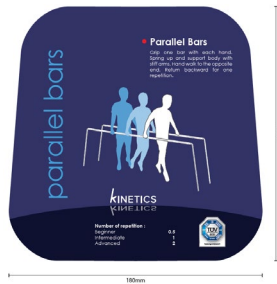

We will continue to make product improvement and reserve the right to change design specification without notice.

tuv-sud.com/pe-cert  
Certification No. Z2 102633 0001

## Kinetics Play Sdn Bhd

Lot 2-44, Jalan SU7, Lion Industrial Park, Persiaran Tengku Ampuan, 40300 Shah Alam, Selangor, Malaysia.  
Tel: +603-5888 9104

Email: [info@kineticsplay.com](mailto:info@kineticsplay.com)

Web: [www.kineticsplay.com](http://www.kineticsplay.com)