



## Octopia

### Product information

#### Product description

This vibrant octopus-shaped play structure sparks imagination and active engagement. Its dynamic design offers climbing, hiding, and crawling opportunities through tentacle-inspired openings. Inside, children can relax in hammocks, creating a cozy "inner world."

Category	: Thematic
Age group	: 5-12 years old
Product Code	: CV0137SM
Sizes (mm)	: L5490 x H2795 x W4820 mm



Subject to change without prior notice.

### KINETICS PLAY SDN. BHD. (1223254-U)

Lot 2-44 Jalan SU7, Lion Industrial Park, Persiaran Tengku Ampuan, 40300 Shah Alam, Selangor, Malaysia.  
Tel: +603-5888 9104 Email: [info@kineticsplay.com](mailto:info@kineticsplay.com) Web: [www.kineticsplay.com](http://www.kineticsplay.com)

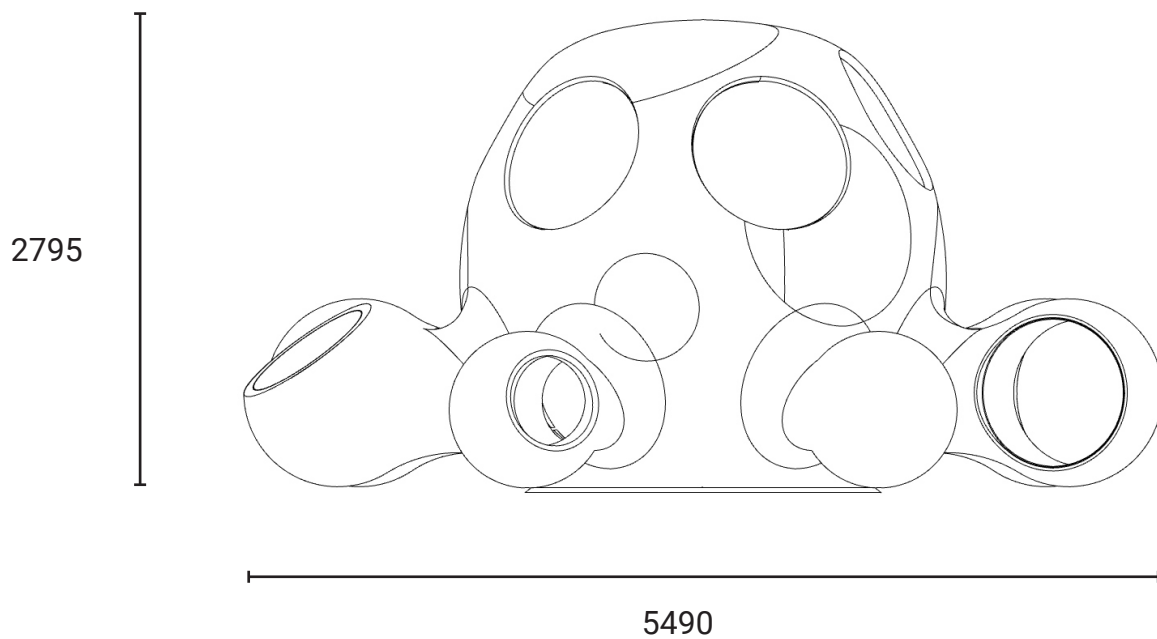
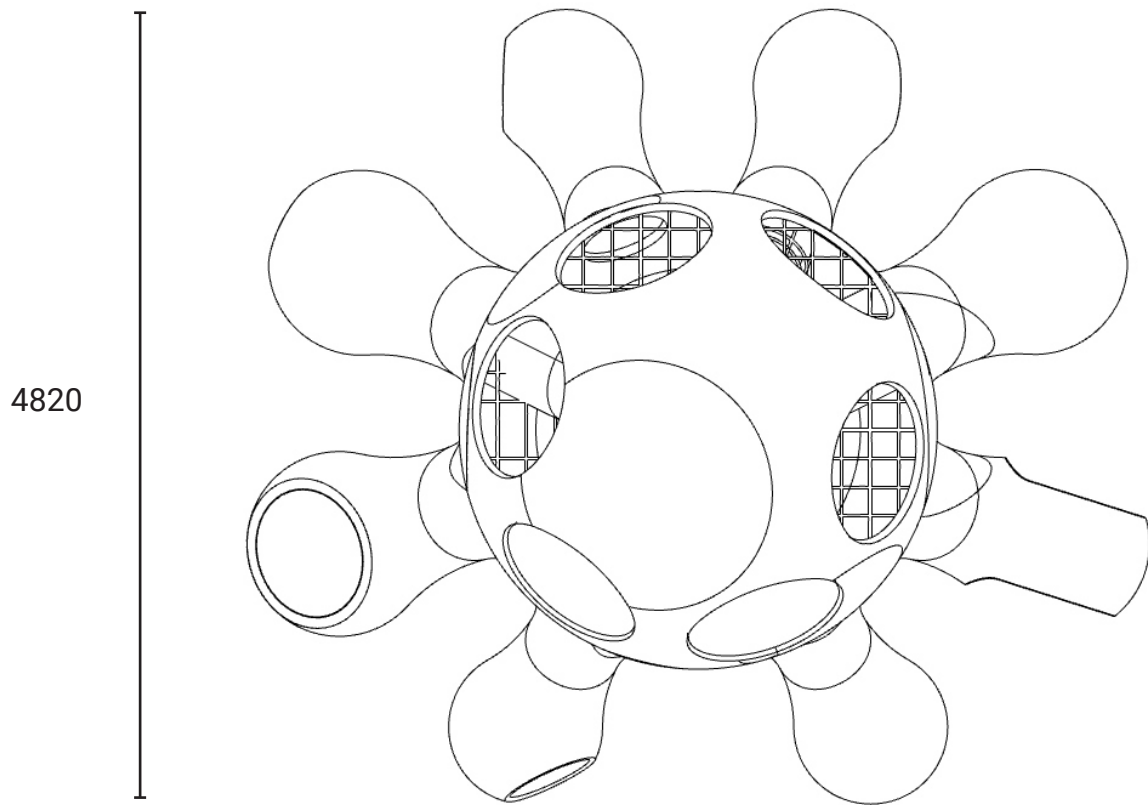

Subject to change without prior notice.

**KINETICS PLAY SDN. BHD. (1223254-U)**

Lot 2-44 Jalan SU7, Lion Industrial Park, Persiaran Tengku Ampuan, 40300 Shah Alam, Selangor, Malaysia.  
Tel: +603-5888 9104      Email: [info@kineticsplay.com](mailto:info@kineticsplay.com)      Web: [www.kineticsplay.com](http://www.kineticsplay.com)